

Halsey Taylor Owners Manual

4720 Freeze Resistant Bi-Level Steel Fountain

STOP! **PLEASE READ THE FOLLOWING** **INFORMATION.**

- **INSTALLATION INSTRUCTIONS FOR THE 4720FR FTN. WITH 97482C DUAL VALVE CONTROL ASSEMBLY ARE LOCATED ON PAGES 2 - 5.**
- **INSTALLATION INSTRUCTIONS FOR THE 4720FR FTN. WITH SANITARY FR2 VALVE ARE LOCATED ON PAGES 6 - 12.**

INSTALLER

Halsey Taylor Fountains are among the easiest to install Fountains on the market today. To assure you install these models easily and correctly, PLEASE READ THESE SIMPLE INSTRUCTIONS BEFORE STARTING THE INSTALLATION. CHECK YOUR INSTALLATION FOR COMPLIANCE WITH PLUMBING, ELECTRICAL, AND OTHER APPLICABLE CODES. After installation, leave these instructions with the Fountain for future reference.

IMPORTANT

THE GROUNDING OF ELECTRICAL EQUIPMENT SUCH AS TELEPHONE, COMPUTERS, ETC. TO WATER LINES IS A COMMON PROCEDURE. THIS GROUNDING MAY BE IN THE BUILDING OR MAY OCCUR AWAY FROM THE BUILDING. THIS GROUNDING CAN CAUSE ELECTRICAL FEEDBACK INTO A FOUNTAIN, CREATING AN ELECTROLYSIS WHICH CAUSES A METALLIC TASTE OR AN INCREASE IN THE METAL CONTENT OF THE WATER. THIS CONDITION IS AVOIDABLE BY USING THE PROPER MATERIALS AS INDICATED. ANY DRAIN FITTINGS PROVIDED BY THE INSTALLER SHOULD BE MADE OF PLASTIC TO ELECTRICALLY ISOLATE THE FOUNTAIN FROM THE BUILDING PLUMBING SYSTEM.

IMPORTANT

ALL SERVICE TO BE PERFORMED BY AN AUTHORIZED SERVICE PERSON

Halsey Taylor Owners Manual

4720 Freeze Resistant Bi-Level Steel Fountain with 97482C Dual Valve Control Assembly

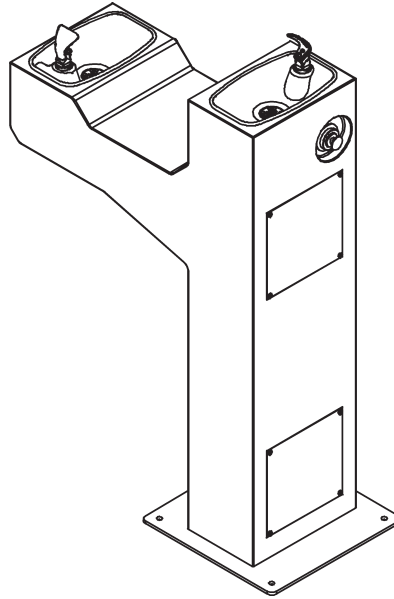

IMPORTANT! INSTALLER PLEASE NOTE

Do not pull up on lines coming out of the PVC column. Use the nylon strap (ref. 17) to lift the unit to prevent damage to the valve.

General Installation Tips

1. Be sure to flush water supply line before you connect it to the inlet fitting on Freeze Resistant Valve System.
2. There are two drain lines required for this unit. One for the drinking fountain basin drain and one for the valve/water supply line system. The bowl drain is the 3/4" PVC fitting at the bottom of the 6" PVC tube and the valve drains through the small holes in the PVC cap. Provide ample drainage for these two items. It's always better to have too much than not enough.
3. The column (6" PVC tube) must remain vertical. Be sure it remains vertical when backfilling the excavating trench.
4. When the concrete pad, for mounting the fountain, is poured, be sure to allow adequate space around the top of the column so that the flexible cap may be removed for servicing the valve.
5. We recommend that the top of the column be flush or slightly above the top height of the concrete pad.
6. You should test the unit before you backfill. Simply blow on the clear, small diameter tubing. A steady stream should flow from the braided tubing line. When air pressure is removed from the clear tubing the water stream should stop.
7. Once you have tested the valve, backfilled the hole and poured the concrete mounting pad you are ready to set the fountain. After bolting the fountain in place connect the air control valve tubing, supply water tubing and drain lines. The water supply line must have a straight run from the basin bubbler down to the control valve. If a straight run is not maintained water will become trapped and freeze leaving the unit inoperable. Test the fountain again. If it fails to work, the air control line may be kinked or connected improperly. Be sure to keep water out of the air control line.
8. These products are designed to operate on 20 PSI to 105 PSI supply line pressure. If inlet pressure above 105 PSI, a pressure regulator must be installed in the supply line. Any damage caused by reason of connecting this product to supply line pressure lower than 20 PSI or higher than 105 PSI is not covered by warranty.

**SITE PREPARATION DETAIL FOR THE
4720FR FTN. WHEN USING 97482C DUAL VALVE CONTROL ASSY.**

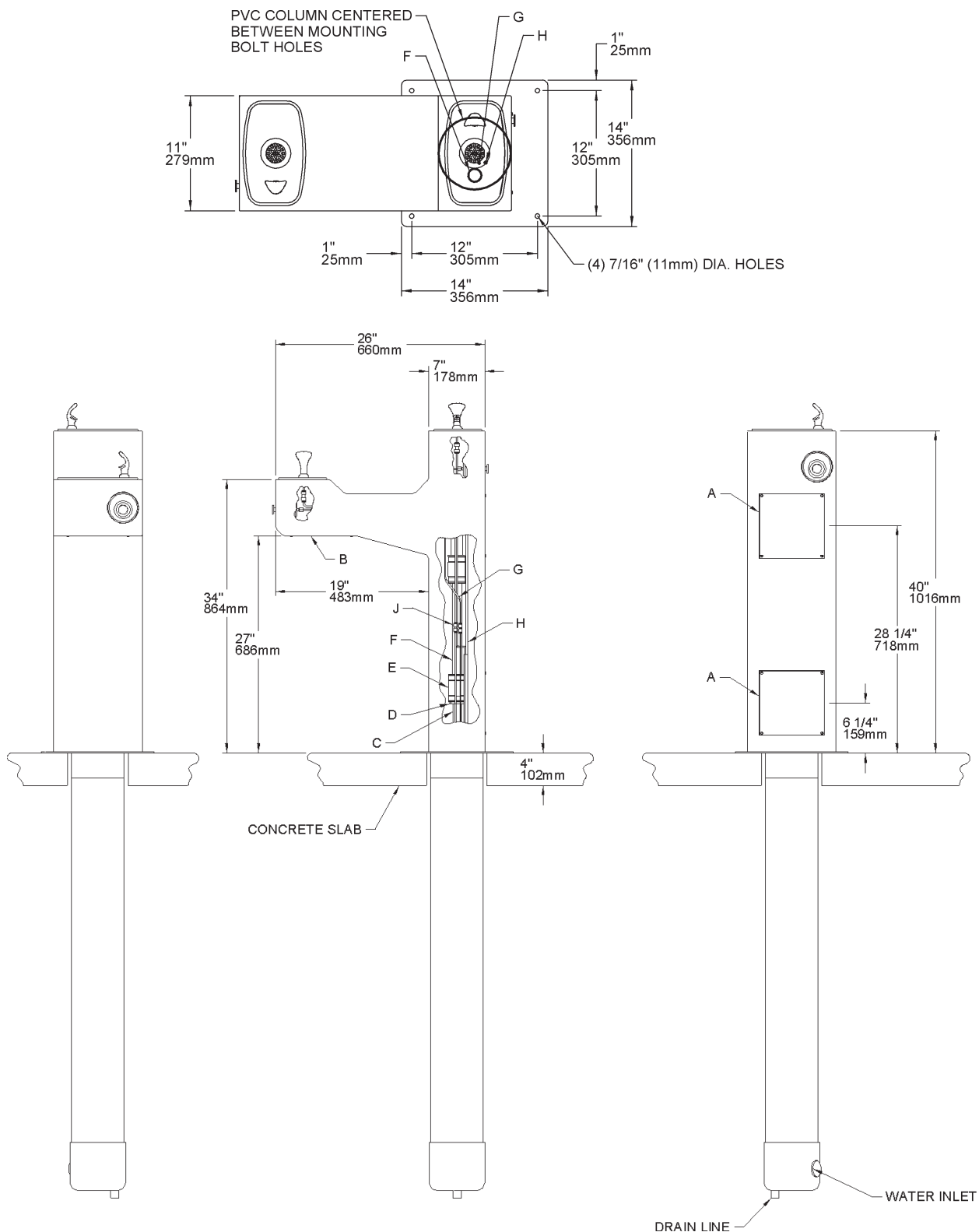

LEGEND

- A = ACCESS PANEL
- B = REMOVABLE BOTTOM COVER
- C = 1" PVC DRAIN
- D = PRESSURE FITTING 1-1/4" x 3/4"
- E = CONNECTOR 1-1/4" TO 1-1/4"

- F = 1-1/4" DRAIN TUBE
- G = AIR CONTROL LINE
- H = 1/4" WATER LINE
- J = CONNECTOR FOR AIR CONTROL LINE

FIG. 1

INSTALLATION INSTRUCTIONS FOR INSTALLING 97482C DUAL VALVE CONTROL ASSY.

1. Prepare trench for water supply and waste drain lines (if required by local codes). The hole should be deep enough to accommodate the PVC column and 5 cubic feet of porous fill (large broken rock). Additional porous fill may be required due to local ground conditions. (See Site Preparation Detail below).
2. Lay drain lines and water supply lines. Provide service shut-off valve for maintenance. Flush the water supply line before attaching to the shut-off valve.
3. Set PVC column in excavating pit. Connect the water supply line to the inlet on the PVC column. Remove valve assembly from the PVC column by carefully pulling up on the connecting tubing. Pressure test the valve assembly for leaks. Check operation of the water valve by blowing on the small clear diameter tubing. A steady stream of water should flow from the braided tubing. After releasing air pressure from the small clear tubing the water stream should stop.
4. Replace the water valve into the PVC column. Make sure the supply hose coils into the bottom of the PVC column without any kinks. Cap the PVC column, protect the ends of the connecting tubes and backfill the trench. Keep the PVC column vertical at all times.
5. Form the concrete mounting pad and locate the fountain anchor bolts in the proper position. (Refer to Rough-in for correct location of anchor bolts.) Pour concrete and finish. Be sure to keep concrete away from the top of the PVC column to allow removal of PVC cap to allow for future service. Let concrete set 24 hours minimum before mounting fountain.
6. Double check that the water valve is positioned fully at the bottom of the PVC column. Install insulation into the PVC column and push down onto the top of the water valve.
7. Mount the fountain onto the anchor bolts. Level and shim fountain as required.
8. Connect the drain line, water line and air control lines. Excess lengths should be trimmed from the tubing. The water supply line must be positioned for positive drain back out of the fountain and down through the water valve. **Any water allowed to be trapped above the frost line will freeze leaving the unit inoperable.** Do not pull up on the connection lines as this could raise the valve above the frost line.
9. Check for proper operation by using fountain push button. If the valve does not work properly check for leaks or kinks in the air control line.
10. After insuring proper operation reassemble fountain. Installation of your fountain is now complete.

**SITE PREPARATION DETAIL
FIG. 2**

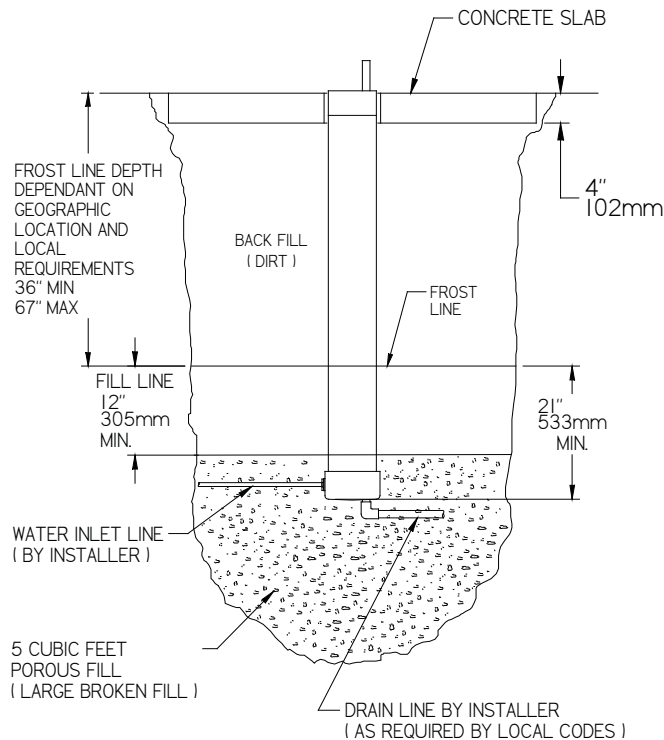

Troubleshooting

Insufficient Bubbler Flow: Check that the shut-off valve is wide open. Verify minimum 20 PSI supply pressure. Clean inlet strainer screen located in the valve body. Clean rubber orifice in flow control located below frost line in bushing between barb fitting and valve.

No Flow: Check for leaks in the air tubing going from the push button to the valve. Make sure the air tubing compression nut is hand tight. Disconnect air tube from push button. Place finger over air outlet. Push button to test diaphragm. Tighten diaphragm cap screws. Replace diaphragm if necessary.

Continued Insufficient or Varied Height of Bubbler Flow:

- Replace flow control.
- Check for kinks in the tubing.
- Remove the PVC cap from the PVC column. Remove the valve assembly from the PVC column by carefully pulling up on the connecting tubing. Pressure test the valve assembly for leaks. Check stream height from the bubbler. Stream height is factory set at 35 PSI. If supply pressure varies greatly from this, adjust the screw on the regulator (Item 26, Page 5, Stream Height Adjustment Detail). Clockwise adjustment will raise stream and counter-clockwise adjustment will lower stream. For best adjustment stream height should be approx. 1-1/2" (38mm) above the bubbler guard. Replace the valve into the PVC column. Make sure the supply hose coils into the bottom of the PVC column without any kinks and double check that the valve is positioned fully at the bottom of the PVC column. Cap the PVC column.

Continuous Bubbler Flow: Insure that push button is not obstructed and springs back to normal position. Remove four screws which secure plastic diaphragm block to valve body. Pull plastic and rubber diaphragm assembly out of valve body. Locate tiny hole in rubber diaphragm just under lip of plastic part. Clean debris from this hole. Inspect valve seat for grooves. If valve seat was OK and diaphragm hole was free from debris, inspect rubber button located at center of floating steel disc in valve diaphragm block assembly. If button is worn, turn disc over or replace it. If diaphragm and seats are in good condition, stretch spring slightly. Spring is located behind floating stainless steel plate. Insure that air bleed port on valve plastic block assembly is not plugged.

The following items are included with the 4720FR Fountain

PARTS LIST		
ITEM NO.	PART NO.	DESCRIPTION
1	100147140560	Drain Gasket
2	100322740560	Gasket
3	101449542550	Clamp - Hose
4	101570540560	Drain Gasket
5	15013C	Bubbler Tube Assy.
6	15014C	Retaining Nut
7	110544942550	Set Screw #8-32 x .125
8	110868642550	Socket Head Screw #10-24 x .75
9	160270508640	Strainer Plate
10	170705042830	Basin
11	28091C	Nameplate Insert
12	40045C	Hex Nut 1-5/16"
13	45851C	Bubbler
14	40250C	Tailpipe 1-1/4" x 5-3/8"
15	45403C	Push Button Actuator
16	45476C	Drain Tube
17	45830C	Fountain Body
18	45842C	Access Panel
19	45663C	Push Button Sleeve
20	50986C	Regulator Holder
21	55913C	Drain Adapter
22	55960C	Pressure Fitting 1-1/4" To 3/4"
23	56082C	Regulator Nut
24	56121C	Drain Elbow 1-1/4"
25	600985451640	Drain Plug Assy.
26	61313C	Regulator
27	66346C	Drain Tube
28	66461C	Fitting 1-1/4" x 1-1/4"
29	66719C	Tube Assy.
30	70683C	Union 1/4"
31	75534C	Pinned Torx Screw #10-24
32	75565C	Fitting - Double Male Connector
33	75588C	Slip Joint Nut 1-1/4"
34	75589C	Gasket
35	97482C	Dual Control Valve System Complete
*36	45971C	Dual Control Valve Assy.
37	45788C	Rainbird Check Valve
38	45790C	Flow Control Fitting
39	45793C	Dual Acorn Valve Assy.
NS	75520C	Bit - Pinned Torx T-25
NS	75596C	Paint Touch-up (Pen)
NS	56092C	Poly Tubing - 1/4" (Cut To Length) - To Bubbler
NS	56123C	Poly Tubing - 1/8" (Cut To Length) - To Actuator
NS	75539C	Nameplate Insert

* Includes items 37, 38, 39

Touch-up Paint

For minor scratches a Touch-up Paint Stick is available. For repairing large defects, off-the-shelf aerosol paint from your local hardware store can be used. Listed are two suggested brandnames.

- Brandname: X-O
XO-11 Hunter Green
- Brandname: Ace Hardware
Rust Stop / Machine & Implement International Green

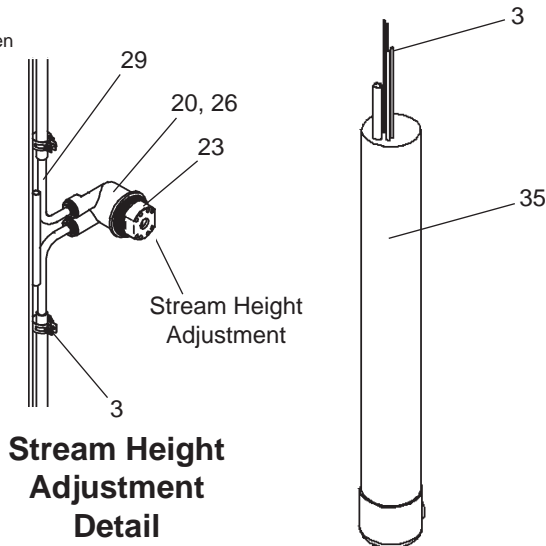
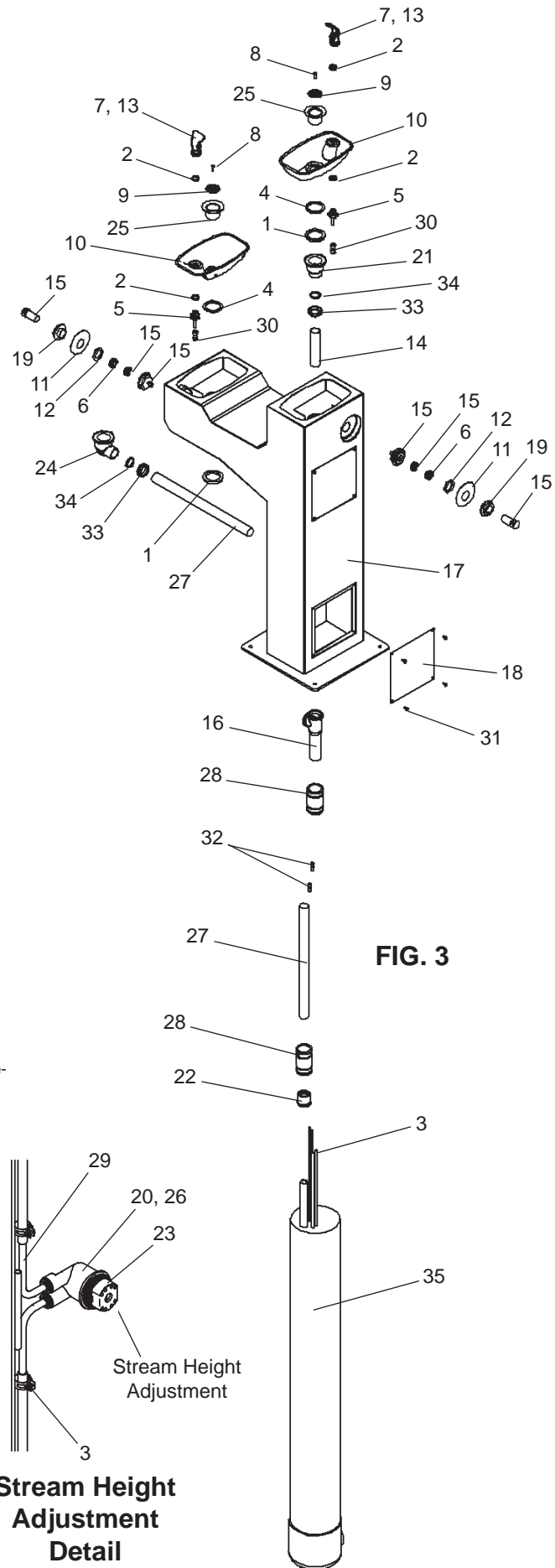
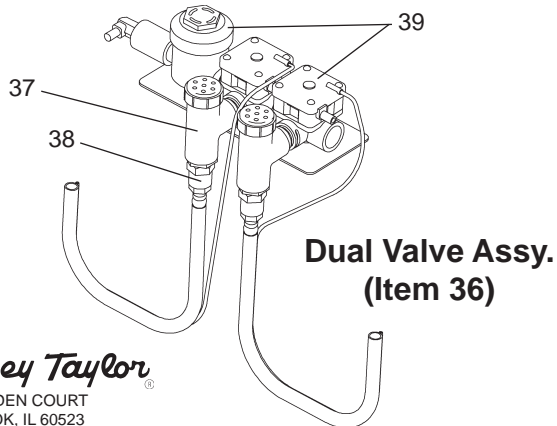

Halsey Taylor
2222 CAMDEN COURT
OAK BROOK, IL 60523
630.574.3500

PRINTED IN U.S.A.

FOR PARTS, CONTACT YOUR LOCAL DISTRIBUTOR OR VISIT OUR WEBSITE WWW.HALSEYTAYLOR.COM

Halsey Taylor Owners Manual

4720 Freeze Resistant Floor Mounted Steel Fountain with Sanitary FR2 Valve

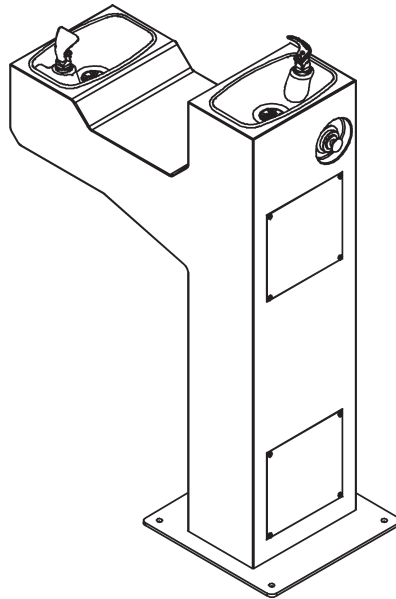

IMPORTANT! INSTALLER PLEASE NOTE

Tubing must be cut to the right length. Do not coil any excess tubing or it will cause valve to malfunction.

General Installation Tips

1. Prepare trench for water supply and waste drain lines. The hole should be deep enough to accommodate the PVC column. Additional porous fill and drain pipe may be required due to local ground conditions. Cut the PVC column to fit desired bury depth. Set PVC column in excavating pit.
2. Lay drain lines and water supply lines. Provide service shut-off valve for maintenance. Flush the water supply line before attaching to the shut-off valve.

Other Notes:

- The details on the attached pages show a suggested installation method. Depending on the climate and environmental conditions the suggested installation may be modified.
- Overall - for the freeze resistant to function properly the valve must be installed in a non-freezing area.

SUGGESTED SITE PREPARATION DETAIL FOR THE 4720FR FTN. WHEN USING THE SANITARY FR2 VALVE

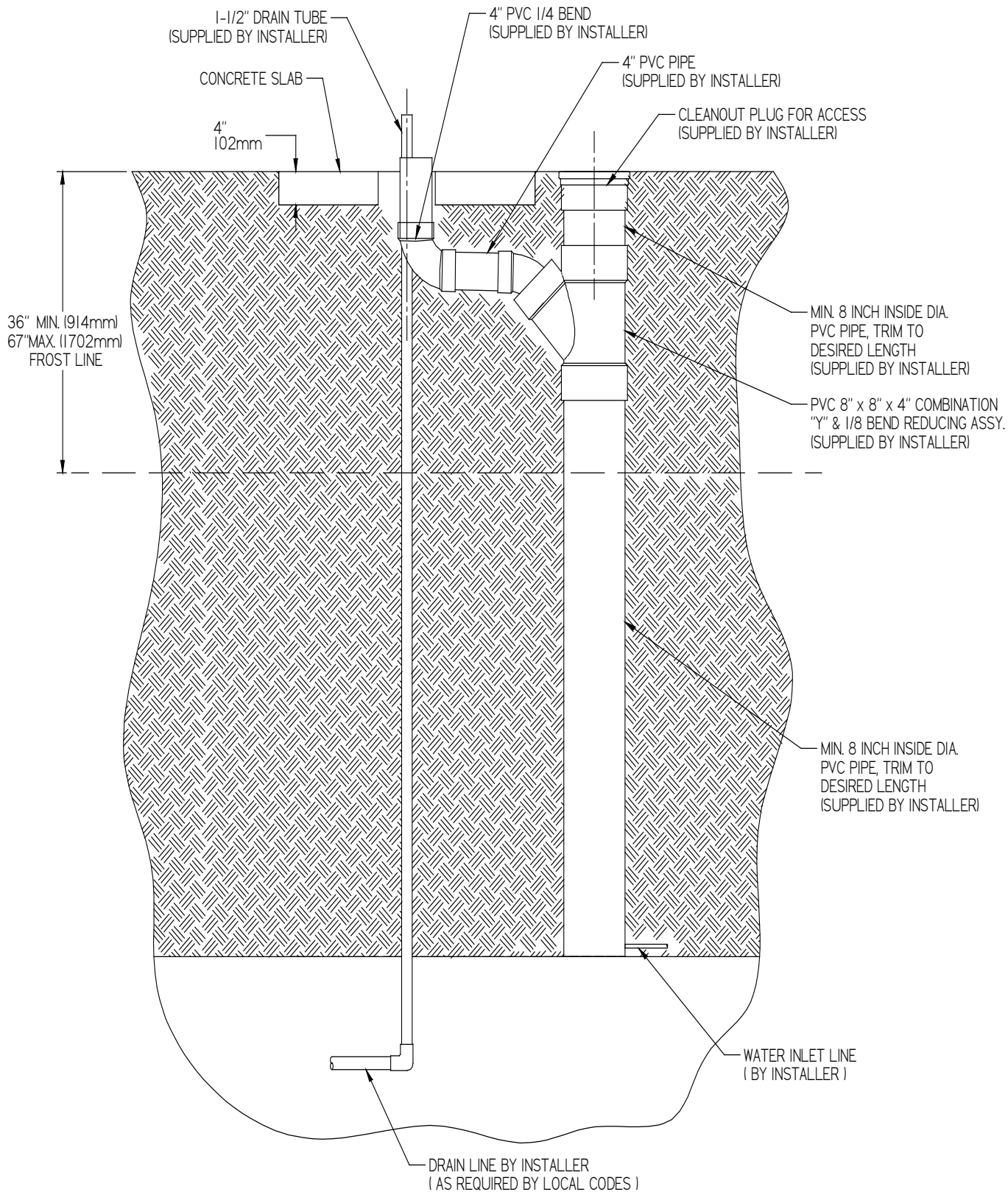
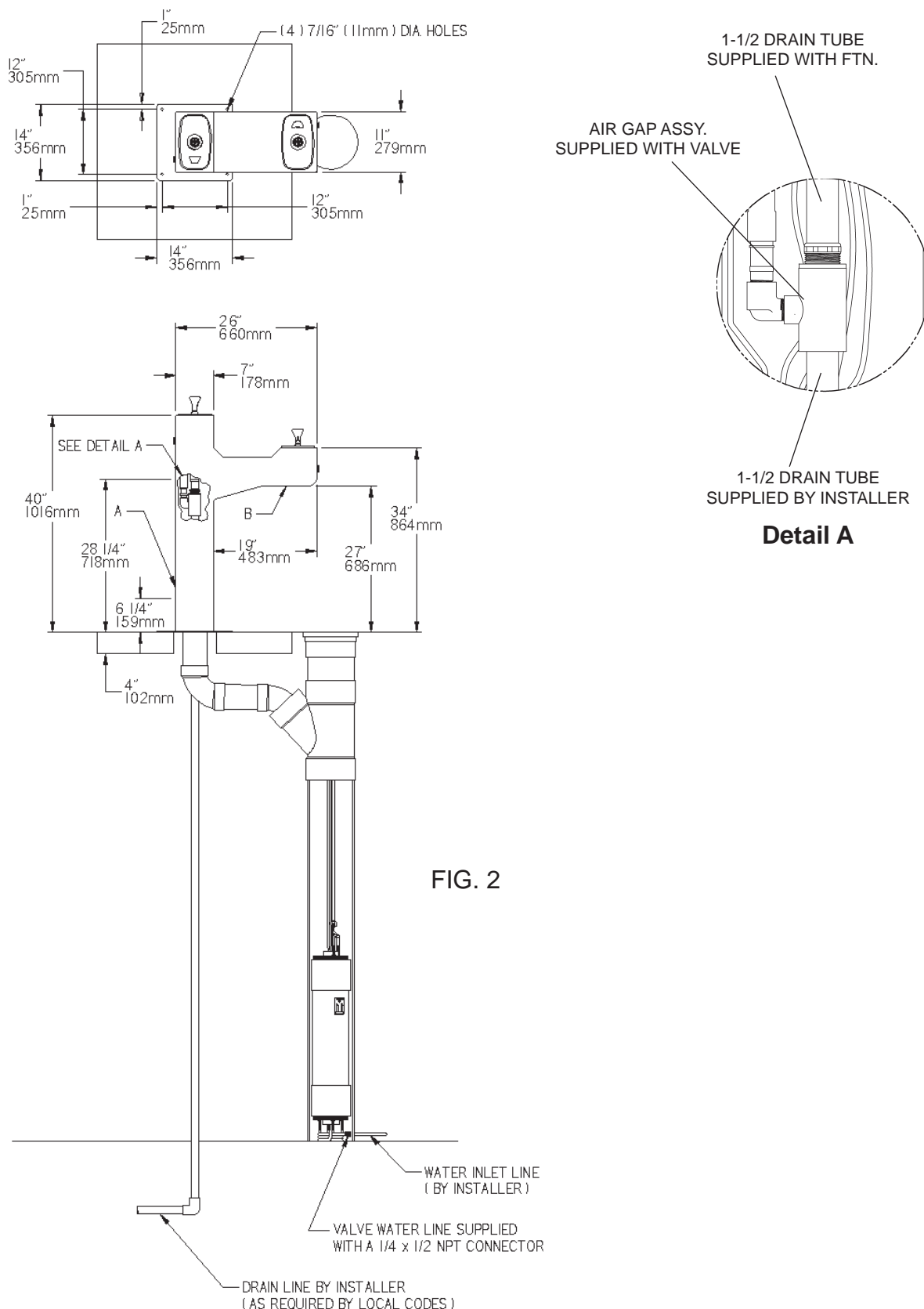

FIG. 1

SUGGESTED SITE PREPARATION DETAIL FOR THE 4720FR FTN. WHEN USING THE SANITARY FR2 VALVE



LEGEND

- A = ACCESS PANEL (8" X 10")**
- B = REMOVABLE BOTTOM COVER**

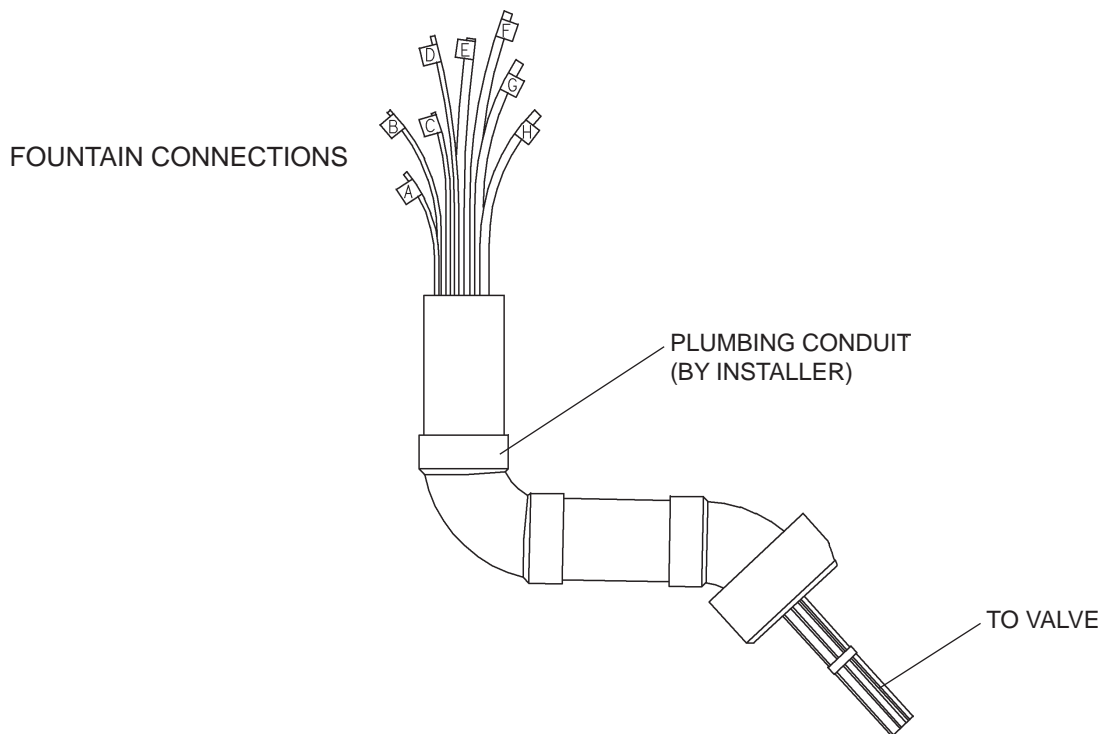
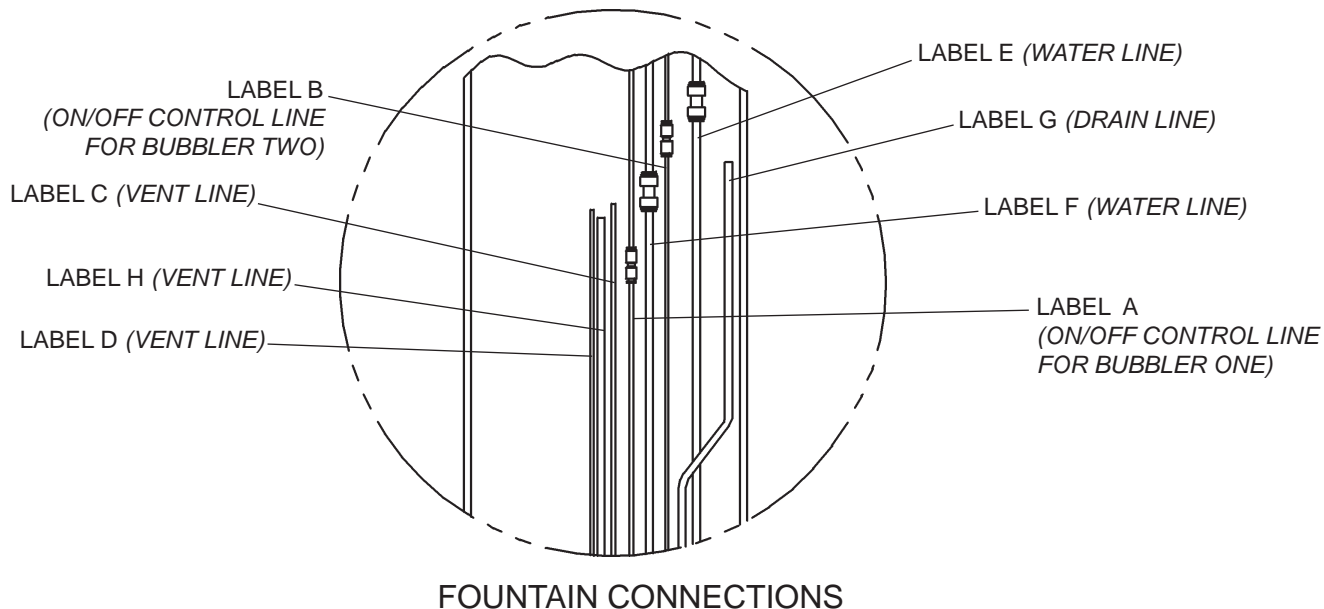

FIG. 3

INSTRUCTIONS FOR CONNECTING TUBES FROM VALVE TO FOUNTAIN(S)

- Step 1 - Insert the 1/8" O.D. tube(s) (Labeled A & B) into the connector(s) (provided with fountain). Insert the 1/8" O.D. tube(s) coming from the fountain(s) push button actuator(s) into the connector(s). Trim any excess length.
- Step 2 - Secure the 1/8" O.D. tube(s) (Labeled C & D) to the waste line assembly. This line is a vent line and should be open to the air.
- Step 3 - Insert the 1/4" O.D. tube(s) (Labeled E & F) into the 1/4" union(s) (provided with valve assembly). Insert the 1/4" O.D. water lines coming from the fountain(s) into union(s). Trim any excess length.
- Step 4 - Insert the 1/4" O.D. tube (Labeled G) into the air gap assembly.
- Step 5 - Secure the 1/4" O.D. tube (Labeled H) to the waste line assembly. This line is a vent line and should be open to the air.



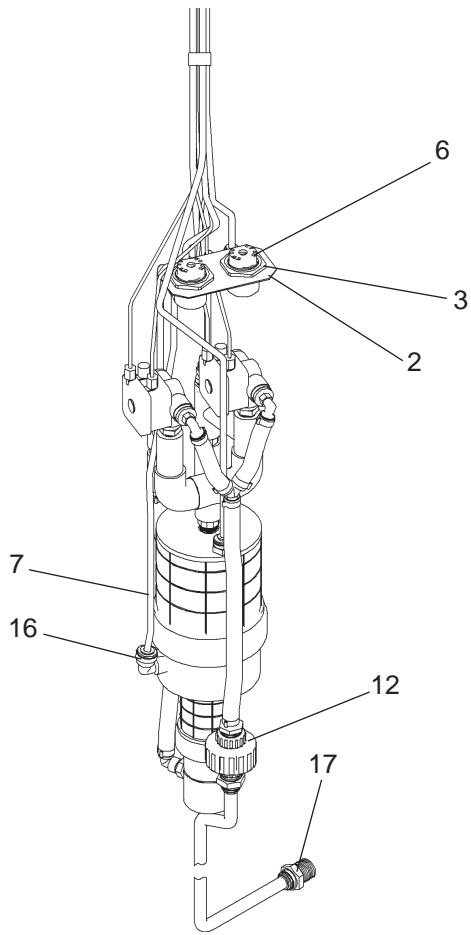

FIG. 4

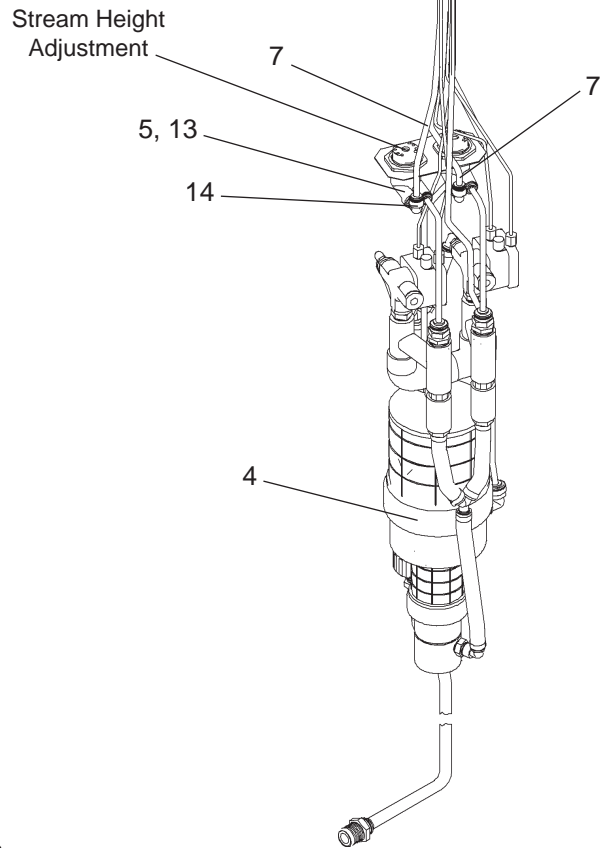

FIG. 5

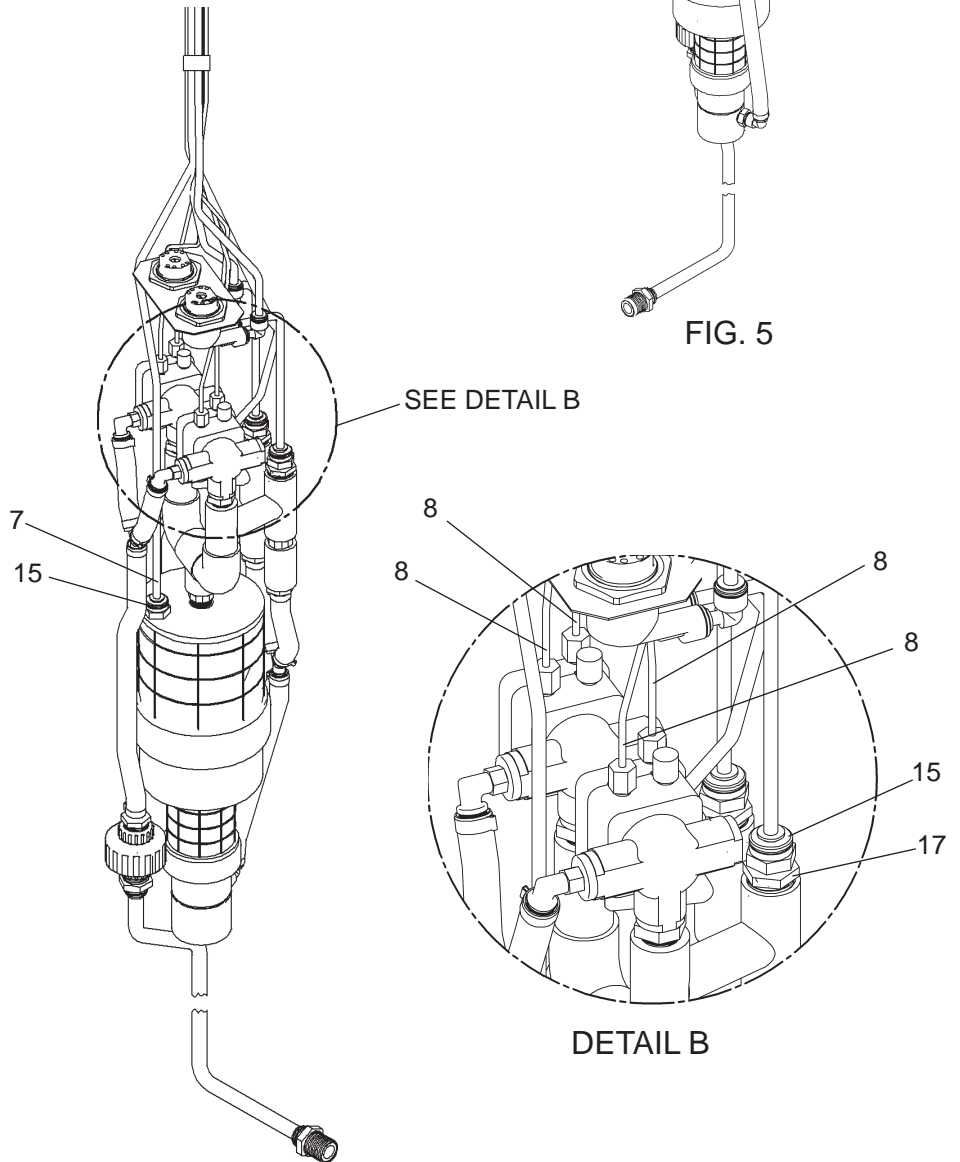

FIG. 6

The Following Items are included with the Sanitary FR2 Valve

PARTS LIST		
ITEM NO.	PART NO.	DESCRIPTION
1	110175443890	Hex Nut - 3/8-16
2	28424C	Bracket - Regulator Holder
3	40045C	Hex Nut - 1-5/16
4	45807C	Dual Valve
5	50986C	Regulator Holder
6	56082C	Regulator Nut
7	56092C	Poly Tubing - 1/4" (Cut To Length)
8	56123C	Poly Tubing - 1/8" (Cut To Length)
9	56185C	Canister
10	56187C	Trap - Adaptor 1-1/2
11	56203C	Air Gap Assy.
12	56235C	Fitting - 1/2" Union w/Strainer
13	61313C	Regulator
14	70817C	Fitting - Elbow 1/4 Stem x 1/4 Tube
15	70828C	Fitting - Connector 1/4 x 1/4 NPTF
16	75639C	Fitting - Elbow 1/4 x 1/4 NPTF
17	75642C	Fitting - Adaptor 1/4 NPT x 1/2 NPT
18	75652C	U-Bolt
19	75653C	Nylon Strap - 6 ft.
NS	70683C	Fitting - Union 1/4

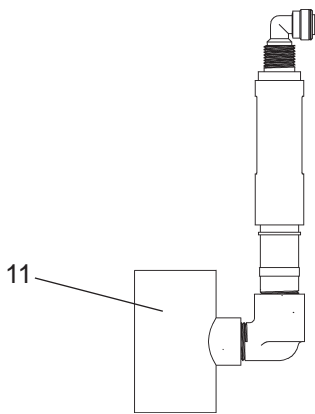

FIG. 7

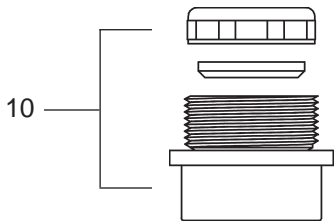

FIG. 8

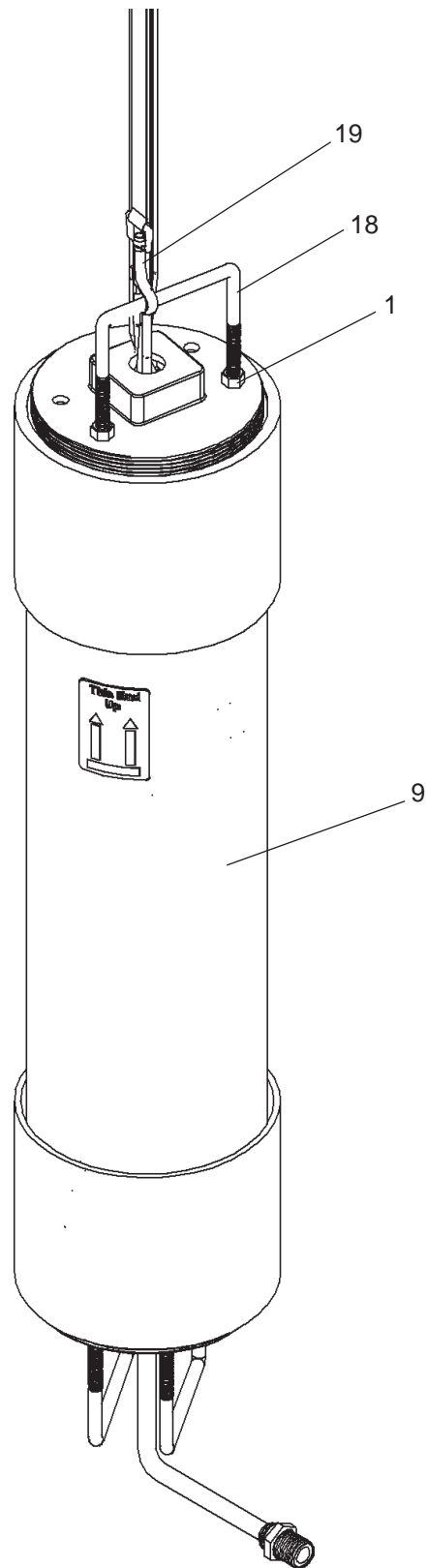

FIG. 9

The following items are included with the 4720FR Fountain

PARTS LIST		
ITEM NO.	PART NO.	DESCRIPTION
20	100147140560	Drain Gasket
21	100322740560	Gasket
22	101570540560	Drain Gasket
23	15013C	Bubbler Tube Assy.
24	15014C	Retaining Nut
25	110544942550	Set Screw #8-32 x .125
26	110868642550	Socket Head Screw #10-24 x .75
27	160270508640	Strainer Plate
28	170705042830	Basin
29	28091C	Nameplate Insert
30	40045C	Hex Nut 1-5/16"
31	45851C	Bubbler
32	40250C	Tailpipe 1-1/4" x 5-3/8"
33	45403C	Push Button Actuator
34	45476C	Drain Tube
35	45830C	Fountain Body
36	45842C	Access Panel
37	45663C	Push Button Sleeve
38	55913C	Drain Adapter
39	56121C	Drain Elbow 1-1/4"
40	600985451640	Drain Plug Assy.
41	66346C	Drain Tube
42	70683C	Union 1/4
43	75534C	Pinned Torx Screw #10-24
44	75588C	Slip Joint Nut 1-1/4"
45	75589C	Gasket
NS	75520C	Bit - Pinned Torx T-25
NS	75565C	Fitting - Double Male Connector
NS	75596C	Paint Touch-up (Pen)
NS	56092C	Poly Tubing - 1/4" (Cut To Length) - To Bubbler
NS	56123C	Poly Tubing - 1/8" (Cut To Length) - To Actuator
NS	75539C	Allen Wrench

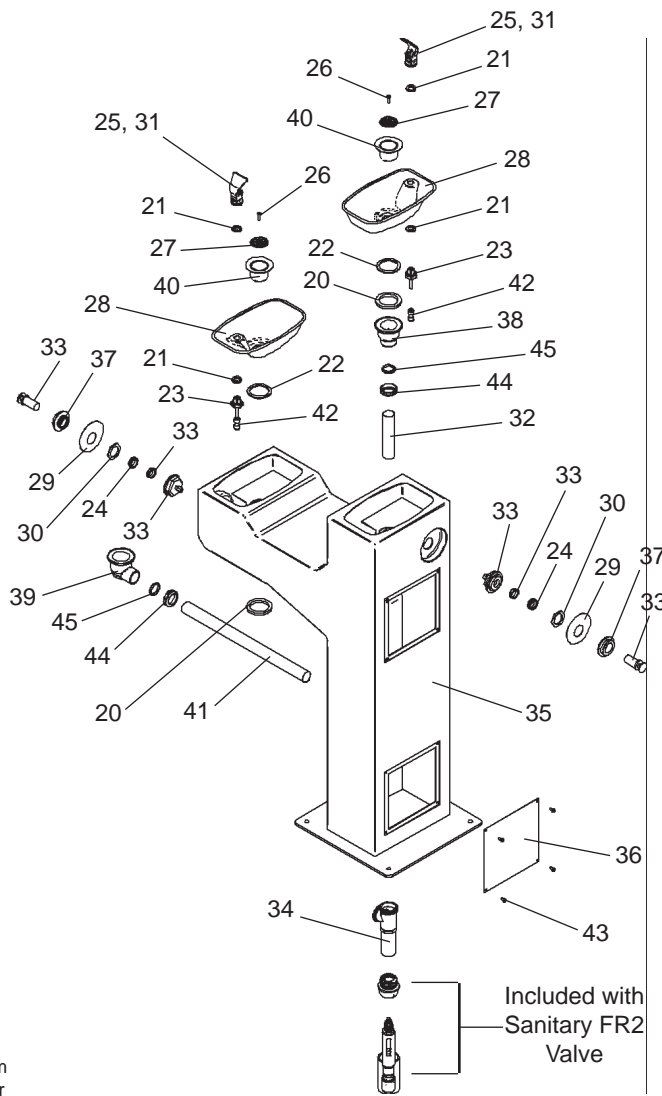

FIG. 10

Troubleshooting

Insufficient Bubbler Flow: Check that the shut-off valve is wide open. Verify minimum 20 PSI supply pressure. Clean inlet strainer screen located in the valve body. Clean rubber orifice in flow control located below frost line in bushing between barb fitting and valve.

No Flow: Check for leaks in the air tubing going from the push button to the valve. Make sure the air tubing compression nut is hand tight. Disconnect air tube from push button. Place finger over air outlet. Push button to test diaphragm. Tighten diaphragm cap screws. Replace diaphragm if necessary.

Continued Insufficient or Varied Height of Bubbler Flow:

- Replace flow control.
- Check for kinks in the tubing.
- Remove the cleanout plug from the PVC column. Remove the valve assembly from the PVC column by carefully pulling up on the strap and connecting tubing at the same time. Pressure test the valve assembly for leaks. Check stream height from the bubbler. Stream height is factory set at 35 PSI. If supply pressure varies greatly from this, adjust the screw on the regulator (Item 13, Fig. 5, Page 10). Clockwise adjustment will raise stream and counter-clockwise adjustment will lower stream. For best adjustment stream height should be approx. 1-1/2" (38mm) above the bubbler guard. Replace the valve into the PVC column. Make sure the supply hose coils into the bottom of the PVC column without any kinks and double check that the valve is positioned fully at the bottom of the PVC column. Cap the PVC column.

Continuous Bubbler Flow: Insure that push button is not obstructed and springs back to normal position. Remove four screws which secure plastic diaphragm block to valve body. Pull plastic and rubber diaphragm assembly out of valve body. Locate tiny hole in rubber diaphragm just under lip of plastic part. Clean debris from this hole. Inspect valve seat for grooves. If valve seat was OK and diaphragm hole was free from debris, inspect rubber button located at center of floating steel disc in valve diaphragm block assembly. If button is worn, turn disc over or replace it. If diaphragm and seats are in good condition, stretch spring slightly. Spring is located behind floating stainless steel plate. Insure that air bleed port on valve plastic block assembly is not plugged.

Halsey Taylor

2222 CAMDEN COURT
OAK BROOK, IL 60523
630.574.3500

FOR PARTS, CONTACT YOUR LOCAL DISTRIBUTOR OR VISIT OUR WEBSITE WWW.HALSEYTAYLOR.COM

PRINTED IN U.S.A.